



**PRODUCT SPECIFICATION OF Oupiin**

# PRODUCT SPECIFICATION

## 產品規格書

產品名稱	產品料號 Part No.	圖號 Drawing No.
9391 Series Male/Female Press Fit Type	9391-x(Pxx)(Sxx)(Pxx)CxxPxA(-Axxx)	9391-D0000-xxx
	9391-x(Pxx)(Sxx)(Pxx)CxxPA(-Axxx)	9391-D0000-xxx
	9391-Ax(Pxx)(Sxx)(Pxx)CxxPxA(-Axxx)	9391-D0000-xxx
	9391-x(Pxx)(Sxx)(Pxx)CxxPxA(-Axxx)	9391-D0000-xxx
	9391-x(Xxx)(X)(Xxx)(X)(Xxx)(X)(Xxx)CBxxDxA(-Axxx)	9391-D0000-xxx
	9391-x(Xxx)(X)(Xxx)(X)(Xxx)(X)(Xxx)CBxxPxA(-Axxx)	9391-D0000-xxx

PRODUCT NAME 產品名稱	DOCUMENT No.: 文件編號	Rev. 版本	OUPIIN
9391 Series Male/Female Press Fit Type	Q9391-PSS-001	Q	歐品電子
	<b>Approved</b> 核准	<b>Checked</b> 審核	<b>Prepared</b> 製作
			XS 04/13'24



# PRODUCT SPECIFICATION OF Oupiin

## 1. COPE 適用範圍

This product specification defines the product performance and the test methods to ascertain the performance of the 9391 Series Male/Female Press Fit Type Connector which is designed and manufactured by Oupiin Electronic Co., Ltd. This product specification is applicable but not only for those part numbers which be shown in the cover page.

本產品規格書規定了由歐品電子有限公司設計生產的 9391 Series Male/Female Press Fit Type 型連接器·產品的特性及測試方法。本產品規格書適用於但不局限於封面所顯示的產品料號。

## 2. REFERENCE DOCUMENTS 參考文件

MIL-STD-1344	Test method for electrical connector 電子連接器測試方法
MIL-STD-202	Test method for electrical components 電子零件測試方法
EIA364	Test method for electrical components 電子零件測試方法
JIS C 0051	Test method for electrical components 電子零件測試方法
MIL-G-45204C	Specification for gold plating 鍍金規格
IEC-512-3	IEC standard for current carrying capacity tests IEC 電流測試標準
QQ-N-290A	Specification for nickel plating 鍍鎳規格
MIL-P-81728A	Specification for tin/lead plating 鍍錫鉛規格
MIL-T-10727B	Specification for tin plating 鍍錫規格
UL1977	UL standard for safety of attachment plug and receptacle UL 安規要求標準
EN/ISO5961	Determination of total lead & cadmium content 總鉛和總鎘含量測定
EN1122	Determination of total lead & cadmium content 總鉛和總鎘含量測定
EN13346	Determination of heavy metals content 重金屬含量測定
EPA3052	Determination of total lead & cadmium content 總鉛和總鎘含量測定

## 3. FEATURE & DIMENSIONS 特徵及尺寸

### 3.1. PRODUCT DIMENSION 產品尺寸

These connectors shall have the dimensions as shown in drawing.

本產品的相關尺寸參見圖面。

### 3.2.MALE AND FEMALE PRODUCT 公母產品裝配

#### 3.2.1.Male Female assembly dimension 公母產品裝配尺寸

# PRODUCT SPECIFICATION OF Oupiin

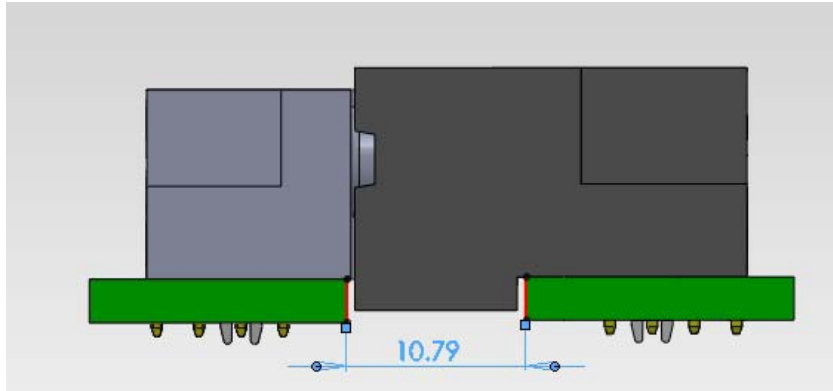

Distance between male's PCB and female's PCB is 10.79REF

公母 PCB 板之間的尺寸為  
10.79REF

### 3.2.2 Perpendicular to engaging direction 垂直插入方向

the design of the centering and guiding in the Mpc of the free and fixed board connector modules shall accept a misalignment of 2.50mm in transverse and 3.00mm in longitudinal axes of the connector  
固定板連接器模件的 Mpc 裡，連接器設計中心線橫向可接受 2.50mm 和縱向可接受 3.00mm 的偏差。

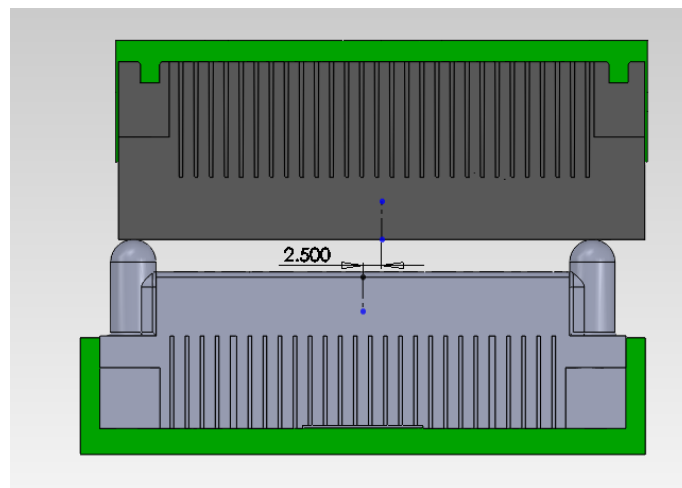

allowed misalignment in transverse axes 在橫向方向允許對插偏差量

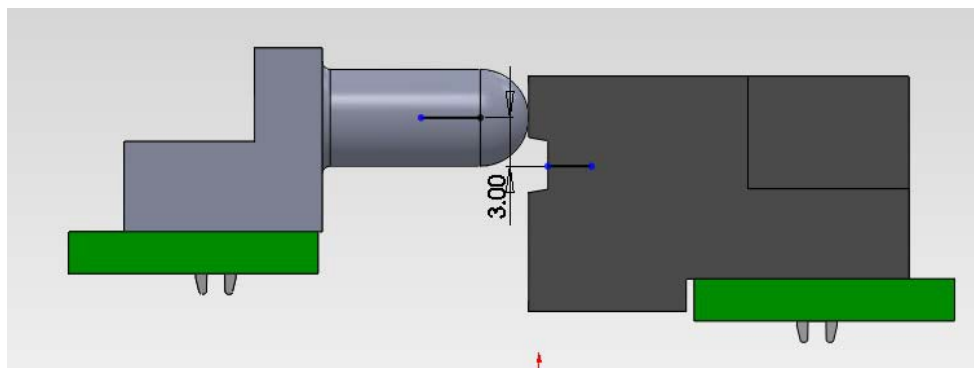

allowed misalignment in longitudinal axes 在縱向方向允許對插偏差量

# PRODUCT SPECIFICATION OF Oupiin

## 3.2.3 inclination 傾向

The center and guiding in the Mpc of the free and the fixed board connector modules shall allow an initial angular misalignment of 2° from both the transverse and longitudinal axes

固定板連接器模件的在 Mpc 裡, 連接器可接受橫向和衝向 2° 的最大傾斜對插角度。

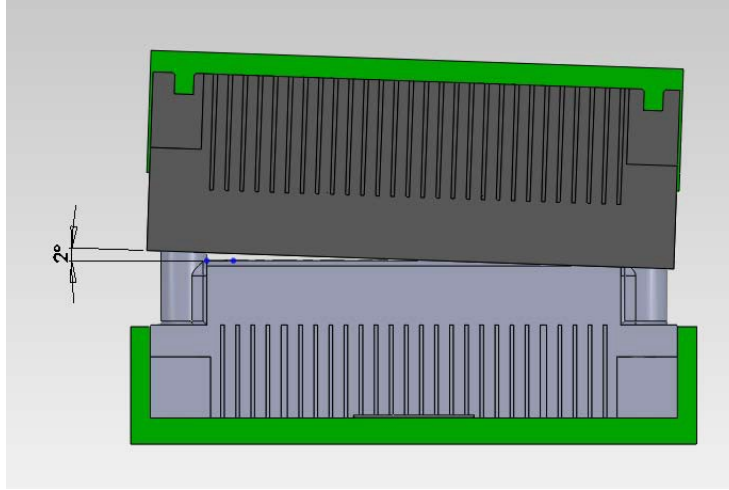

allowed an initial angular misalignment in transverse axes 在橫向方向允許的最大傾斜對插角度

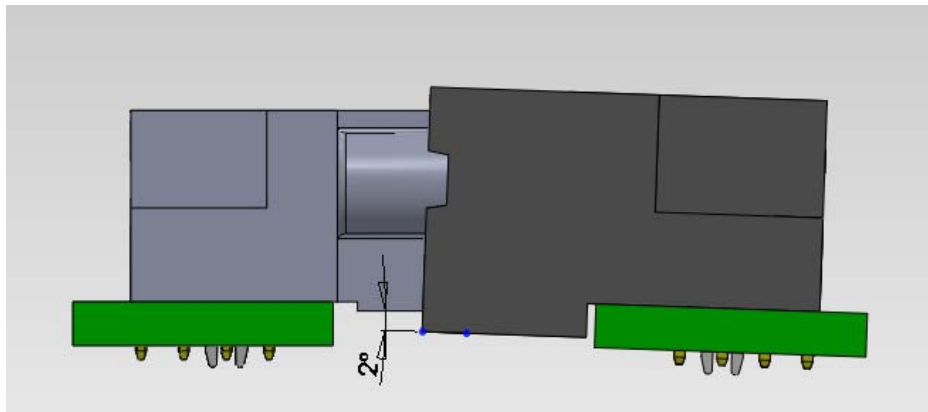

allowed an initial angular misalignment in longitudinal axes 在縱向方向允許的最大傾斜對插角度

## 3.2.4. Capability for products wipe length

產品接觸長度等級

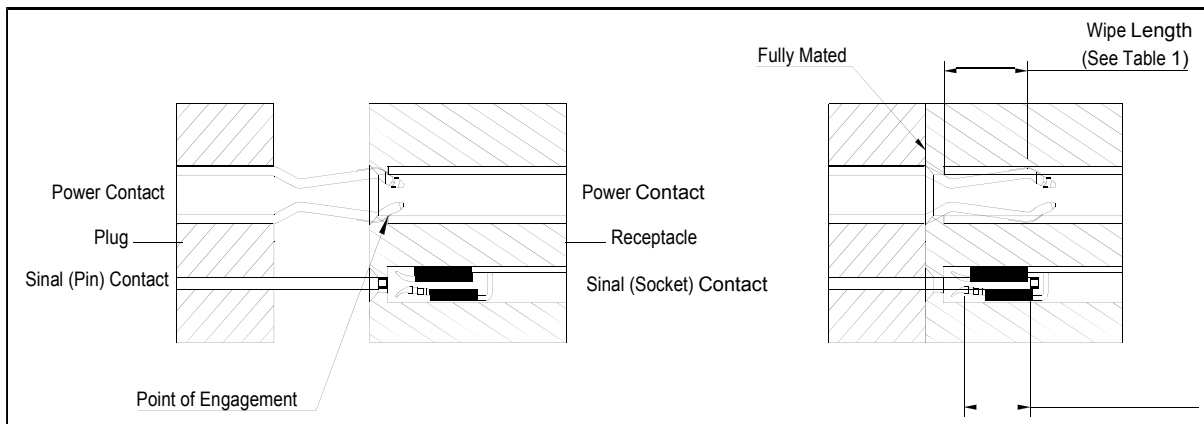



# PRODUCT SPECIFICATION OF Oupiin

CONTACT	MATING LEVEL	WIPE LENGTH(Min)	DESCRIPTION OF DRAWING
High Power	1	4.88	FS
	2	3.61	FM
Low Power	2	3.61	NA
	3	2.59	NA
Signal	1	3.47	F
	2	3.28	G
	3	2.01	E
	4	0.74	H

Table 1

### 3.3. PCB/PANEL LAYOUT 印刷電路板佈局

The recommended PCB layout is shown in drawing.  
本產品適用的 PCB layout 參見圖面。

### 3.4. BILL OF MATERIAL 材料清單

Harmful material controlling follows the requirements of RoHS. The bill of material is described in drawing.  
有害物質控制符合 RoHS 指令要求。本產品使用的材料參見圖面。

### 3.5. MECHANICAL & ELECTRICAL CHARACTERISTIC 機械及電氣特性

The connector shall have the mechanical and electrical performance as described in drawing.  
本產品的機械及電氣特性參見圖面。

### 3.6. PACKAGING 包裝

Products shall be packaged according to requirements specified in purchase order for safe delivery, connector container and the packaging method are shown in package specification. 產品可依客戶指定要求包裝，包裝材料與包裝方式參見產品包裝規範。

### 3.7. RATING CURRENT AND RATING VOLTAGE 額定電流與額定電壓

Signal Pin rating current: Signal Pin 2.5A、  
信號 Pin 額定電流: Signal Pin 2.5A、  
Power Pin rating current:  
電源 Pin 額定電流:



# PRODUCT SPECIFICATION OF Oupiin

Types	Pitch (mm)	Single Contact	2 Adjacent Contacts	4 Adjacent Contacts	12 Adjacent Contacts
Power Contact	5.08	60A	45A	36A	30A
	6.35	60A	45A	38A	30A
	7.62	60A	45A	42A	30A

rating voltage: Signal Pin:50V DC RMS 、 Power Pin:200V DC RMS.

額定電壓: Signal Pin 50V DC RMS 、 Power Pin:200V DC RMS.

### 3.8. STORAGE AND OPERATING TEMPERATURE 存貯與使用溫度

Temperature range: -40°C~+105°C, including terminal temperature rise for rating current.

Time limit is 18 months the products are stored

溫度範圍: -40°C~+105°C, 包含接觸端子的額定電流溫升, 產品限存時間為 18 個月。

## 4 PERFORMANCE AND TEST DESCRIPTION 性能及測試

### 4.1. REQUIREMENT 要求

Product is designed to meet electrical, mechanical, and environmental performance requirements specified in **Table II**.

本產品設計符合附表二所列的機械、電氣及環境要求。

### 4.2. TEST CONDITION 測試條件

Unless otherwise specified, all tests shall be performed at ambient environmental conditions.

除非特別注明, 所有測試在室溫條件下完成。

### 4.3. SAMPLE SELECTION 樣品選擇

Test samples shall be selected at random from current production. No test samples shall be reused.

Samples are pre-conditioned with 10cycles of durability. Each group shall be containing 5 test samples at least.

測試樣品從現生產的產品中隨機抽取, 所有測試過的樣品不得重複使用。樣品已預先插拔 10 次, 每組測試至少有 5 個樣品。

### 4.4. TEST SEQUENCE 測試順序

Product qualification test sequence as shown in **Table III**.

產品品質測試順序見附表三。



# PRODUCT SPECIFICATION OF Oupiin

**Table II: Test Requirements and Methods**

附表二：測試要求與方法

Items 項目	Requirements 要求	Test Methods 測試方法
1. Confirmation of Product 產品確認	Product shall be conforming to the requirements of applicable product drawing. 產品必須符合相關產品圖面的要求。	Visually, dimensions and functionally inspected per applicable product drawing. 依相關產品圖面，檢查產品的外觀、尺寸及功能。
2. Signal Contact Resistance 信號接觸阻抗	Signal Pin:15 mΩ Max. Signal Pin:最大 15 mΩ。	Subject mated contacts assembled in housing to closed circuit of 20mA max, Test Voltage – 20 mV DC max. 所述固定在外殼裏的端子連接到一個封閉回路中測試，電流最大 20mA，電壓最大 20mV DC。
	Per EIA 364 TP06 適用：EIA 364 TP06	
3. Power Contact Resistance 電源接觸阻抗	Power Pin:0.70 mΩ Max. Power Pin:最大 0.70 mΩ。	Subject mated contacts assembled in housing to closed circuit of 20mA max, Test Voltage – 20 mV DC max.. 所述固定端子連結到一個封閉回路中測試，電流最大 20mA，電壓最大 20mV DC。
	Per EIA 364 TP06 適用：EIA 364 TP06	
4. Insulation Resistance 絕緣阻抗	Signal Pin:5000 MΩ Min. Power Pin:20000 MΩ Min. Signal Pin:最小 5000 MΩ。 Power Pin:最小 20000 MΩ。	a. Test Voltage 500V DC b. Electrification time—2 minutes c. Points of Measurement—Between adjacent Contacts a. 測試電壓 500 V DC b. 電氣化時間-2 分鐘 c. 測量點-相鄰觸點之間
	Per EIA 364 TP21 適用：EIA 364 TP21	
5. Dielectric Withstanding Voltage 耐電壓	There shall be no evidence of arc-over, insulation breakdown, or excessive leakage current (>1 mA) when mated connectors are tested 測試配對連接器時，不應出現電弧過度，絕緣擊穿或過大漏電流 (> 1mA) 的情況。	Test Specification : a. Test Voltage – 2500V DC (power), 1000V DC (signal) b. Test Duration – 60 seconds. c. Test Condition – (760 Torr – sea level). d. Points of measurement Between adjacent Contacts



## PRODUCT SPECIFICATION OF Oupiin

	<p>Per EIA 364 TP20 適用：EIA 364 TP20</p>	<p>測試規格：</p> <p>a 測試電壓 – 2500VDC( 電源 )·1000VDC ( 信號 )</p> <p>b 測試持續時間 - 60 秒。</p> <p>c 試驗條件 - ( 760 托 - 海平面 )。</p> <p>d.測量點相鄰點</p>
<p>6. Test temperature rise for rating current 溫升測試</p>	<p>The temperature rise above ambient shall not exceed 30 °C 。 溫升不能超過 30 °C 。</p> <p>Ambient conditions - Still air 25°C 。 周圍環境溫度 25°C 。</p>	<p>Current Rating – See detail in drawing. The temperature rise above ambient shall not exceed 30°C.</p> <p>a. Ambient Conditions – Still air at 25°C</p> <p>b. Stabilize at a single current level until 3 readings at 5 minutes intervals are within 1°C</p> <p>測試電流詳見圖面規格,環境溫度上升不得超過 30°C 以下細節適用：</p> <p>a 環境條件 – 室溫25°C</p> <p>b 在單個電流水準下穩定，直到 5 個間隔的 3 個讀數在 1°C內。</p>
	<p>Per EIA-364-70 適用：EIA-364-70</p>	
<p>7. Mating /Un-mating Force 插入力/拔出力</p>	<p>Mating force</p> <p>Power Pin: 0.709kg/PIN Max Signal Pin: 0.102kg/PIN Max</p> <p>Un-mating force:</p> <p>Power Pin: 0.227kg/PIN Min Signal Pin: 0.02kg/PIN Min</p> <p>插入力</p> <p>Power Pin: 0.709kg /PIN Max Signal Pin: 0.102kg /PIN Max</p> <p>拔出力</p> <p>Power Pin: 0.227kg /PIN Min Signal Pin: 0.02kg /PIN Min</p>	<p>At a speed of 25.4 mm/minute, apply axial insert the mating part into fully or pull out from the subject product. 以 25.4 mm/分鐘的速度，軸向完全插入對配外掛程式到被測產品中或從被測產品中拔出。</p>
	<p>Per EIA-364-13 適用 EIA-364-13</p>	



## PRODUCT SPECIFICATION OF Oupiin

<p>8. Normal Force 正向力</p>	<p>The contact normal force shall not be less than 350 grams per beam for the power contacts and 50grams (nor greater than 120 grams)per beam for the signal contacts 電源每 PIN 不能小於 350g · 信號每 PIN 不能小於 50g 且不能大於 120g</p>	<p>Exert the axial pressure from carrying the plastics under the sub radian highest point at the speed of 25.4mm / minute. 以 25.4mm/分鐘的速度施加軸向壓力從端子弧度最高處下壓到塑膠面。</p>
<p>9. Contact Retention Force 端子保持力</p>	<p>power and signal contacts : 13.6N/Pin. Min. 電源和信號端子：每支最小 13.6N</p> <hr/> <p>Per EIA-364-29 適用：EIA-364-29</p>	<p>Apply axial pull out (push) force at a speed of 12.7 mm/minute on the contact assembled in the housing, Test 30 contacts. 以 12.7mm/分鐘的速度施加軸向拉（推）力從塑膠本體上拔出(頂退)端子，測試 30 支端子。</p>
<p>10. Connector Pin Press in/Retention Force 單只端子壓入&amp;拔出 PCB 孔的力量</p>	<p>Press in Force Signal Pin:(Male)93.4N/PIN Max (Female)26.6N/PIN Max Power Pin: 111.2N/PIN Max</p> <p>Retention in Force Signal Pin:(Male)13.4N/PIN Min (Female)6.7N/PIN Min Power Pin: 22.3N/PIN Min</p> <p>壓入力 Signal Pin: (公端)93.4N/PIN Max (母端)26.6N/PIN Max Power Pin: 111.2N/PIN Max</p> <p>拉出力 Signal Pin: (公端)13.4N/PIN Min (母端)6.7N/PIN Min Power Pin: 22.3N/PIN Min</p>	<p>At a speed of 5.08 mm/minute, apply axial Press in PCB to Right Proston or Pull out from PCB. 以 5.08 mm/分鐘的速度軸向施加壓力將 Press 部分壓入 PCB 孔適當位置或從 PCB 孔中拉出</p>
<p>11. PCB Hole Deformation Radius PCB 孔變形半徑</p>	<p>The average (of 10 holes) hole deformation radius shall be no greater than0.0381mm when measured from the drilled hole. The absolute maximum deformation radius shall not exceed 0.0508mm 從鑽孔測量時，平均（10 個孔）孔變形半徑應不大於 0.0381mm 。絕對最大變形半徑不得超過 0.0508mm</p>	<p>cross-section parallel to board surface. Photograph and measure the hole deformation (deformation on board material) radius at a point 0.254mm from the surface, and the center of the compliant pin section. Include 10 holes. 與電路板表面平行的橫截面。拍攝並測量距表面 0.254mm 處的孔變形（板材變形）半徑，以及柔性銷部分的中心。包含 10 個孔。</p>



## PRODUCT SPECIFICATION OF Oupiin

<p>12. PCB Hole Wall Damage PCB 孔壁損壞</p>	<p>The minimum average (of 10 holes) copper thickness remaining between the compliant pin and the printed wiring board laminate shall not be less than 2oz. In addition there shall be no copper cracks, separations between conductive interfaces, or laminate-to-copper separations.</p> <p>柔性銷和印刷線路板層壓板之間剩餘的最小平均(10個孔)銅厚度應不小於2oz。此外，不應存在銅裂縫導電介面之間的分離或層壓銅分離。</p>	<p>Cross-section perpendicular to the board surface, and through the compliant section wear track. Photograph and measure the copper thickness remaining between the compliant section and the printed wiring board laminate. Include 10 holes.</p> <p>垂直於板表面的橫截面，並通過符合規定的斷面磨損軌跡。拍攝並測量相容的部分和印刷線路板層之間剩餘的銅厚度。包含10個孔。</p>
<p>13. Lock Retention Force Lock 保持力</p>	<p>Lock:13.6N/Pin.Min Lock：每支最小13.6N</p> <hr/> <p>Per EIA-364-29 適用：EIA-364-29</p>	<p>Apply axial pull out (push) force at a speed of 12.7 mm/minute on the Lock assembled in the housing, Test 30 board locks.</p> <p>以12.7mm/分鐘的速度施加軸向拉力從塑膠本體上拔出耳扣，測試30支Lock。</p>
<p>14. Thermal Shock 熱沖擊</p>	<p>After exposure to the following environmental conditions in accordance with the specified test procedure and / or details, the product shall show no physical damage and shall meet the applicable electrical and mechanical requirements of paragraphs 2~13 as detailed in Table III test sequences. Unless otherwise specified, assemblies shall be mated during exposure.</p> <p>在按照規定的試驗程式和/或細節暴露於下列環境條件後，產品應無任何物理損壞，並應滿足表III測試順序中詳述的第2~13項目的適用電氣和機械要求。除非另有規定，否則組件應在暴露期間配合。</p> <hr/> <p>Per EIA-364-32 適用 EIA-364-32</p>	<p>Test Specification :</p> <ul style="list-style-type: none"> <li>a. Test condition – 36 cycles</li> <li>b. Temperature Range – -55 to +125°C</li> <li>c. Time at Each Temperature – To refer to EIA-364-32 based on product mass</li> <li>d. Transfer Time – 5 minutes, maximum</li> </ul> <p>測試規格：</p> <ul style="list-style-type: none"> <li>a. 測試條件 - 循環36次</li> <li>b. 溫度範圍 - -55 to +125°C</li> <li>c. 每個溫度下的時間 - 根據產品品質參考 EIA-364-32</li> <li>d. 轉移時間 - 最多5分鐘</li> </ul>



## PRODUCT SPECIFICATION OF Oupiin

<p>15. Humidity (Steady State) 恆溫恆濕</p>	<p>After exposure to the following environmental conditions in accordance with the specified test procedure and / or details, the product shall show no physical damage and shall meet the applicable electrical and mechanical requirements of paragraphs 2~13 as detailed in Table III test sequences. Unless otherwise specified, assemblies shall be mated during exposure.</p> <p>在按照規定的試驗程式和/或細節暴露於下列環境條件後，產品應無任何物理損壞，並應滿足表 III 測試順序中詳述的第 2~13 項目的適用電氣和機械要求。除非另有規定，否則組件應在暴露期間配合。</p>	<p>a. Relative Humidity - 95% b. Temperature - 40°C c. Test Duration - 96 hours</p> <p>a. 相對濕度 95% b. 溫度 40°C c. 測試持續時間 96 小時</p>
	<p>Per EIA-364-31 適用：EIA-364-31</p>	
<p>16.High Temperature Life 高溫壽命</p>	<p>After exposure to the following environmental conditions in accordance with the specified test procedure and / or details, the product shall show no physical damage and shall meet the applicable electrical and mechanical requirements of paragraphs 2~13 as detailed in Table III test sequences. Unless otherwise specified, assemblies shall be mated during exposure.</p> <p>在按照規定的試驗程式和/或細節暴露於下列環境條件後，產品應無任何物理損壞，並應滿足表 III 測試順序中詳述的第 2~13 項目的適用電氣和機械要求。除非另有規定，否則組件應在暴露期間配合。</p>	<p>a. Test Duration - 21 days b. Temperature - 125 °C c. Pre-condition - Perform number of durability cycles specified for product</p> <p>a. 測試時間 21 天 b. 溫度 125°C c. 前提條件執行為產品指定的耐用性週期數</p>
	<p>Per EIA-364-17 適用：EIA-364-17</p>	



## PRODUCT SPECIFICATION OF Oupiin

<p>17. Environmental Sequence 環境順序</p>	<p>After exposure to the following environmental conditions in accordance with the specified test procedure and / or details, the product shall show no physical damage and shall meet the applicable electrical and mechanical requirements of paragraphs 2~13 as detailed in Table III test sequences. Unless otherwise specified, assemblies shall be mated during exposure.</p> <p>在按照規定的試驗程式和/或細節暴露於下列環境條件後，產品應無任何物理損壞，並應滿足表 III 測試順序中詳述的第 2~13 項目的適用電氣和機械要求。除非另有規定，否則組件應在暴露期間配合。</p>	<p>Phase I – Thermal Shock, EIA 364-32</p> <ul style="list-style-type: none"> <li>a Test Duration – 36 cycles</li> <li>b Temperature Range – Between -55 and +125 °C</li> <li>c Time at Each Temperature – To refer to EIA 364-32 based on product mass</li> <li>d Transfer Time – 5 minutes, maximum</li> </ul> <p>Phase II – Humidity, EIA 364-31, Method II</p> <ul style="list-style-type: none"> <li>a Test Duration – 10 days</li> <li>b Relative Humidity – 95%</li> <li>c Temperature – +40 °C</li> </ul> <p>Phase III – High Temperature Life, EIA 364-17</p> <ul style="list-style-type: none"> <li>a Test Duration – 21days</li> <li>b Temperature – +125 °C</li> <li>c Pre-condition – Perform number of durability cycles specified for product</li> </ul>
	<p>Phase I – Thermal Shock, Per EIA 364-32</p> <p>Phase II – Humidity, Per EIA 364-31, Method II</p> <p>Phase III – High Temperature Life, Per EIA 364-17</p> <p>第一階段 - 熱衝擊 適用 EIA 364-32</p> <p>第二階段 - 恆溫恆濕 · 適用 EIA 364-31 · 方法 II</p> <p>第三階段 - 高溫壽命 · 適用 EIA 364-17</p>	<p>第一階段 - 熱衝擊</p> <ul style="list-style-type: none"> <li>a 測試條件 - 循環 36 次</li> <li>b 溫度範圍 - -55 to +125 °C</li> <li>c 每個溫度下的時間 - 根據產品品質參考 EIA-364-32</li> <li>d 轉移時間 - 最多 5 分鐘</li> </ul> <p>第二階段 - 恆溫恆濕</p> <ul style="list-style-type: none"> <li>a 測試持續時間 - 10 天</li> <li>b 相對濕度 - 95%</li> <li>c 溫度 - +40 °C</li> </ul> <p>第三階段 - 高溫壽命</p> <ul style="list-style-type: none"> <li>a 測試持續時間 - 21 天</li> <li>b 溫度 - +125°C</li> <li>c 前置條件 - 執行完產品指定的耐久性迴圈次數</li> </ul>



## PRODUCT SPECIFICATION OF Oupiin

<p>18. Industrial Mixed Flowing Gas (IMFG) 工業混合流動氣體 (IMFG)</p>	<p>After exposure to the following environmental conditions in accordance with the specified test procedure and / or details, the product shall show no physical damage and shall meet the applicable electrical and mechanical requirements of paragraphs 2~13 as detailed in Table III test sequences. Unless otherwise specified, assemblies shall be mated during exposure.</p> <p>在按照規定的試驗程式和/或細節暴露於下列環境條件後，產品應無任何物理損壞，並應滿足表 III 測試順序中詳述的第 2~13 項目的適用電氣和機械要求。除非另有規定，否則組件應在暴露期間配合。</p>	<p>a Class – IIA b Duration – 20 days c Mated d Test contact resistance after 10 and 20 days</p> <p>a 種類 - IIA b 持續時間 - 20 天 c 對配 d 測試 10 天和 20 天后的接觸電阻</p>
	<p>Per EIA 364-65 適用 EIA 364-65</p>	
<p>19. Vibration 機械振動</p>	<p>After exposure to the following environmental conditions in accordance with the specified test procedure and / or details, the product shall show no physical damage and shall meet the applicable electrical and mechanical requirements of paragraphs 2~13 as detailed in Table III test sequences. Unless otherwise specified, assemblies shall be mated during exposure.</p> <p>在按照規定的試驗程式和/或細節暴露於下列環境條件後，產品應無任何物理損壞，並應滿足表 III 測試順序中詳述的第 2~13 項目的適用電氣和機械要求。除非另有規定，否則組件應在暴露期間配合。</p>	<p>a Condition – III b Vibration Amplitude – 1.524mm DA or ±15G c Frequency Range – 10 to 2000 to 10 Hz d Sweep Time and Duration – 20 minutes per cycle, 4 hours along each of three orthogonal axes (12 hours total) e Mounting – rigidly mount assemblies f No Discontinuities of greater than 10 nano-seconds</p> <p>a 條件 – III b 振動幅度 - 1.524mm DA 或 ± 15G c 頻率範圍 - 10 到 2000 到 10 Hz d 掃描時間和持續時間 - 每個週期 20 分鐘，沿三個正交軸每個 4 小時（總共 12 小時） e 安裝 – 嚴格安裝組件 f 沒有大於 10 納秒的不連續性</p>
	<p>Per EIA 364 TP 28 適用 EIA 364 TP 28</p>	



## PRODUCT SPECIFICATION OF Oupiin

<p>20. Mechanical Shock 機械衝擊</p>	<p>After exposure to the following environmental conditions in accordance with the specified test procedure and / or details, the product shall show no physical damage and shall meet the applicable electrical and mechanical requirements of paragraphs 2~13 as detailed in Table III test sequences. Unless otherwise specified, assemblies shall be mated during exposure.</p> <p>在按照規定的試驗程式和/或細節暴露於下列環境條件後，產品應無任何物理損壞，並應滿足表 III 測試順序中詳述的第 2~13 項目的適用電氣和機械要求。除非另有規定，否則組件應在暴露期間配合。</p>	<p>a Condition A (50G, 11 millisecond half sine wave) b Shocks –3 shocks in both directions along three orthogonal axes. Total 18 shocks c Installing rigid mounting components d No discontinuities of greater than 10 nano-seconds</p> <p>a 條件 A ( 50G · 11 毫秒半正弦波 ) b 衝擊在三個正交軸的兩個方向上共 3 次沖擊共 18 次 c 安裝 - 嚴格安裝組件 d 沒有大於 10 納秒的不連續性</p>
	<p>Per EIA 364-27 適用 EIA 364-27</p>	
<p>21. Durability (Repeated Mating/Un-mating) 耐久性</p>	<p>After exposure to the following environmental conditions in accordance with the specified test procedure and / or details, the product shall show no physical damage and shall meet the applicable electrical and mechanical requirements of paragraphs 2~13 as detailed in Table III test sequences. Unless otherwise specified, assemblies shall be mated during exposure.</p> <p>在按照規定的試驗程式和/或細節暴露於下列環境條件後，產品應無任何物理損壞，並應滿足表 III 測試順序中詳述的第 2~13 項目的適用電氣和機械要求。除非另有規定，否則組件應在暴露期間配合。</p>	<p>Repeat mate and unmated for connector 200 cycles, at a speed of 127mm per minute. 重復進行配合產品 200 次插拔，速度每分鐘 127mm。</p>
	<p>Per EIA-364-09 適用：EIA-364-09</p>	



## PRODUCT SPECIFICATION OF Oupiin

<p>22. Salt Spray 鹽霧</p>	<p>After exposure to the following environmental conditions in accordance with the specified test procedure and / or details, the product shall show no physical damage and shall meet the applicable electrical and mechanical requirements of paragraphs 2~13 as detailed in Table III test sequences. Unless otherwise specified, assemblies shall be mated during exposure.</p> <p>在按照規定的試驗程式和/或細節暴露於下列環境條件後，產品應無任何物理損壞，並應滿足表 III 測試順序中詳述的第 2~13 項目的適用電氣和機械要求。除非另有規定，否則組件應在暴露期間配合。</p>	<p>5±1% salt concentration(PH=7.0) ,48 hours 35±2°C. 鹽水濃度 5±1%(PH=7.0),時間 48 小時 · 溫度 35±2°C 。</p>
<p>23. Torque Test 扭力測試</p>	<p>After testing, the screws did not slip out, and the plastic did not deform, collapse, or be damaged</p> <p>測試後螺絲無滑出，塑膠無變形、壓垮、壓傷現象。</p>	<p>Rotate the torque tester at a constant speed until the pointer points to 6Kgf.cm.</p> <p>勻速旋轉扭力測試儀，直至指針指向 6Kgf.cm 。</p>
<p>Per EIA-364-26 適用：EIA-364-26</p>		



## PRODUCT SPECIFICATION OF Oupiin

**Table III: Product Qualification Test Sequence**

附表三：產品測試順序

Test Description	PAR	Test Group															
		1	2	3	4	5	6	7	8	9	10	11	12	13	14	15	16
Conformation of Product	1	1 20	1 12	O M	1 8	1 8	O M	1 8	O M	1 3	1 3	1	1 3	O M	1 3	1 11	1 3
Signal Contact Resistance	2	3 6 9 14 17	3 6 10	I T T E D	2 6		I T T E D	2 6	I T T E D					I T T E D		2 7	
Power Contact Resistance	3	4 7 10 15 18	4 7 11		3 7			3 7									3 8
Insulation Resistance	4					2 6											4 9
Dielectric Withstanding Voltage	5					3 7											5 10
Test temperature rise for rating current	6									2							
Mating /Un-mating Force	7	2 11 13 19	2 8														
Normal Force	8																
Contact Retention Force	9												2				
Connector Pin Press in/Retention Force	10										2						
PCB Hole Deformation Radius	11																



## PRODUCT SPECIFICATION OF Oupiin

PCB Hole Wall Damage	12																
Lock Retention Force	13															<b>2</b>	
Thermal Shock	14					<b>4</b>											
Humidity (Steady State)	15					<b>5</b>											
High Temperature Life	16							<b>5</b>									
Environmental Sequence	17																
		<b>5</b>															
		<b>8</b>															
Phase III	<b>16</b>																
Industrial Mixed Flowing Gas (IMFG)	18		<b>9</b>														
Vibration	19					<b>4</b>											
Mechanical Shock	20					<b>5</b>											
Durability (Repeated Mating/Un-mating)	21	<b>12</b>	<b>5</b>						<b>4</b>								
Salt Spray	22															<b>6</b>	
Torque Test	23																<b>2</b>